

# Parts Catalog



*precisely.*



**Model 4600**

## SLICING MACHINES

MODELS:

4600 Rev. B, S/N 461000 & UP

4975 Rev. B, S/N 498001 & UP

7-14-10

IMPORTANT!

TO EXPEDITE SHIPMENT OF PARTS, ALWAYS SPECIFY MODEL, REV,  
PART NUMBER, AND SERIAL NUMBER OF SLICER.

### **GLOBE FOOD EQUIPMENT COMPANY**

2215 East River Road

Dayton, Ohio 45439

#### **Parts Department**

Toll Free 1-800-745-6238 · Fax (937) 290-0585

E-Mail: [globeinfo@globeslicers.com](mailto:globeinfo@globeslicers.com)

Website: [www.globeslicers.com](http://www.globeslicers.com)

Not for resale

## TABLE OF CONTENTS

ACCESSORIES	1
SLICER BASE	2
BASE SHROUD AND COMPONENTS	3
TABLE	4
KNIFE RIM GUARD	5
KNIFE COVER	6
GEAR HOUSING AND KNIFE	7
KNIFE SHARPENER	8-9
KNIFE MOTOR BEARING ASSEMBLY	10
TABLE ADJUSTMENT COMPONENTS	11
TABLE SLIDE SYSTEM	12
KNIFE MOTOR COMPONENTS	13
STAINLESS STEEL CHUTE AND SUPPORT	14
END WEIGHTS	15
MANUAL ELECTRICAL SYSTEM (REV B)	16
AUTOMATIC SLIDE SYSTEM	17
AUTOMATIC DRIVE SYSTEM	18
AUTOMATIC BASE APRON AND LIFT LEVER ASSEMBLY	19
AUTOMATIC ELECTRICAL SYSTEM (REV A)	20
VEGETABLE HOPPER ACCESSORY	21
FRONT MOUNTED END WEIGHT CHUTE ASSEMBLY	22
CHUTE FENCE ACCESSORIES	23
SCHEMATIC 4600	24
SCHEMATIC 4975	25

# ACCESSORIES

VEGETABLE HOPPER 699-BAS

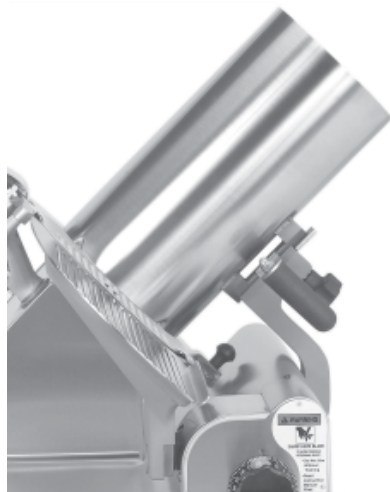

ADJUSTABLE STAINLESS STEEL FENCES  
TALL 1326      SHORT 1047

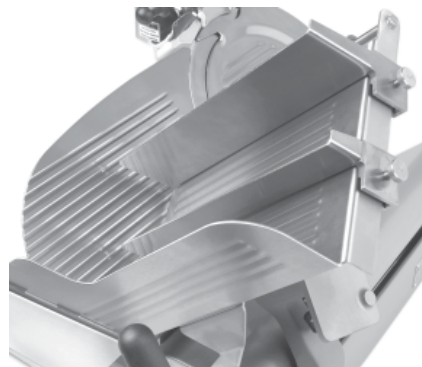

FRONT MOUNTED END WEIGHT 102-AS-21

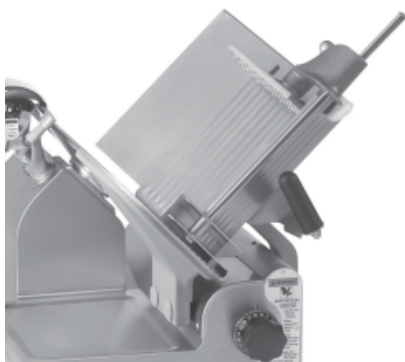

PORTION SCALE PS10



EXTENSION LEGS 873



ACCESSORIES: MODEL 4975A ONLY

ITEM	PART DESCRIPTION	PART NUMBER	QTY
1	FOOT RETAINING KIT	530001	1
2	CLEANING BRUSH, SS STONES	980020	1
3	CLEANING BRUSH	980041	1

# SLICER BASE

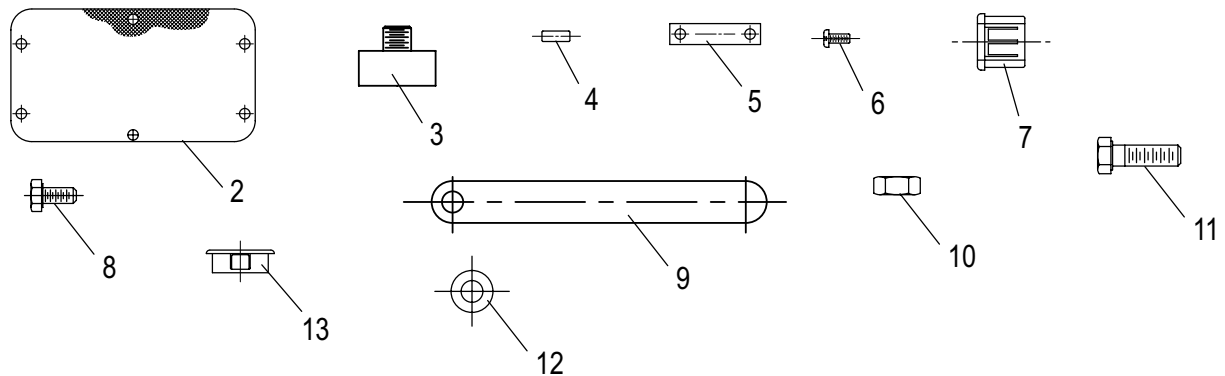
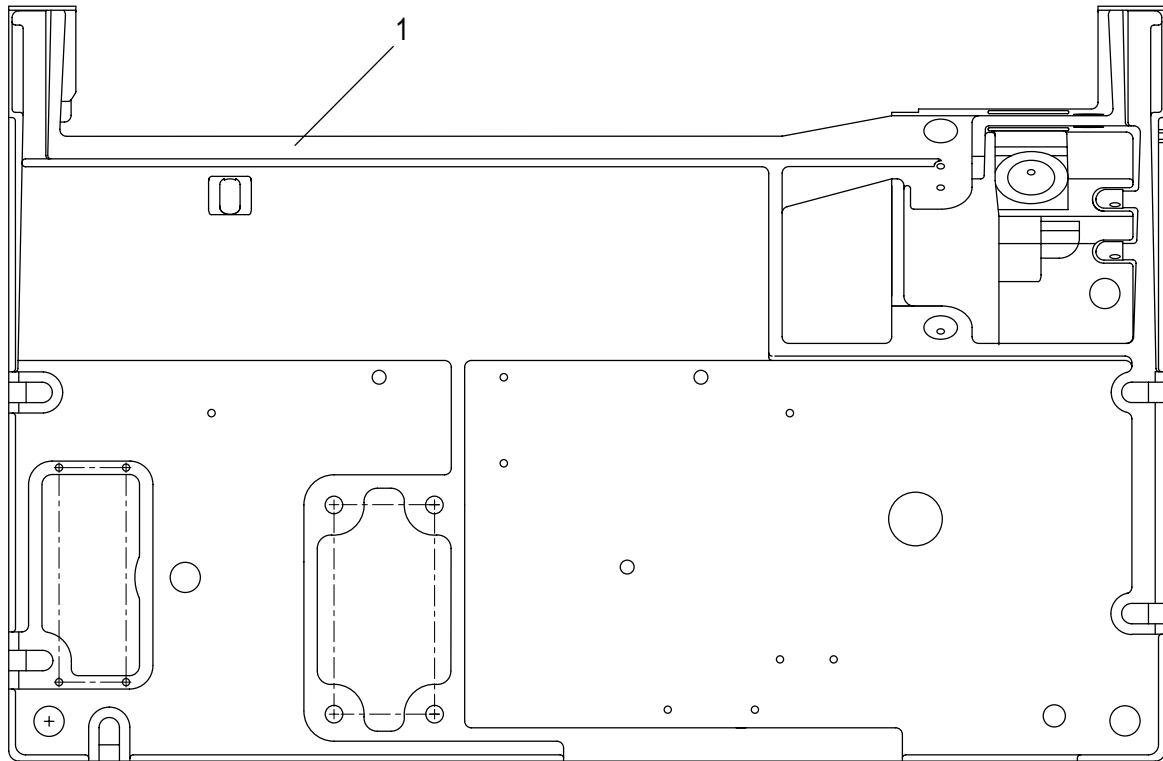

ITEM	PART DESCRIPTION	PART NUMBER	QUANTITY	
			MANUAL	AUTO
1	BASE, MANUAL	1385	1	-
	BASE, AUTOMATIC	1386	-	1
2	MOTOR SCREEN	1148	1	1
3	BASE PAD RUBBER FOOT	817-S	4	4
4	DOWEL PIN	1091	2	2
5	MOTOR SCREEN BRACE	1255	2	2
6	MOTOR BRACE SCREW	1227	4	4
7	SPLIT BUSHING	550002	4	4
8	SCREW, TABLE SLIDE ROD	975-1	1	1
9	CLEANING BRACE	873-CB	1	-
10	NUT	873-CB-1	1	-
11	HEX BOLT	477	1	-
12	FLAT WASHER	763-4A	2	-
13	HOLE PLUG	1208	1	1

# BASE SHROUD AND COMPONENTS

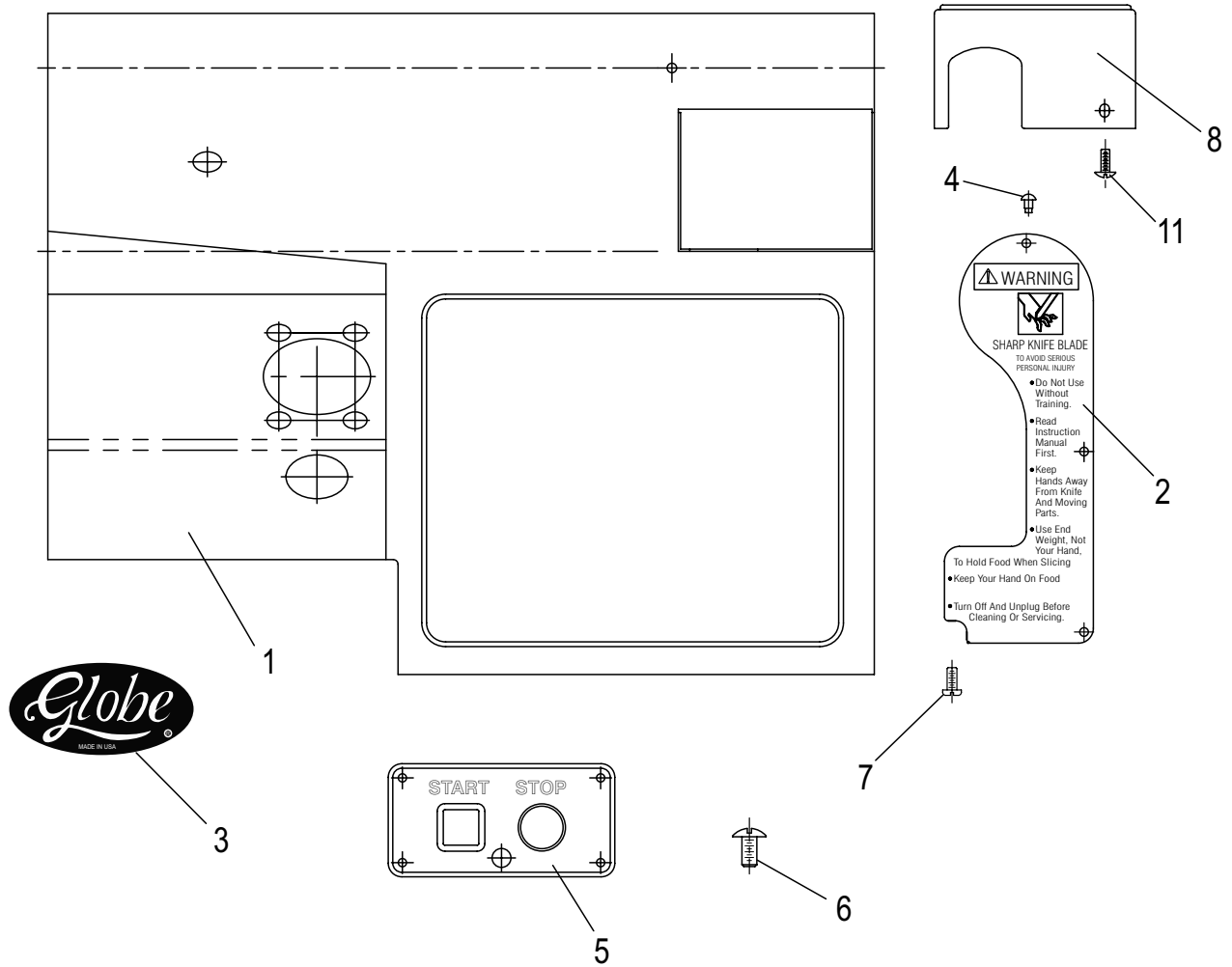

ITEM	PART DESCRIPTION	PART NUMBER	QUANTITY	
			MANUAL	AUTO
1	BASE SHROUD, MANUAL	1338	1	-
	BASE SHROUD, AUTOMATIC	1337	-	1
2	WARNING DECAL - ENGLISH	967-1	1	1
	WARNING DECAL - SPANISH	967-1S	1	1
	WARNING DECAL - FRENCH	967-1F	1	1
3	GLOBE LOGO DECAL	871-2	1	1
4	DRIVE SCREW	851-6P	7	3
5	SWITCH COVER	1157	1	-
6	SCREW	762-6	2	2
7	SCREW	1227	1	1
8	TABLE MECHANISM COVER	1075	1	1
11	SCREW	900-1	1	1

# SLICER TABLE

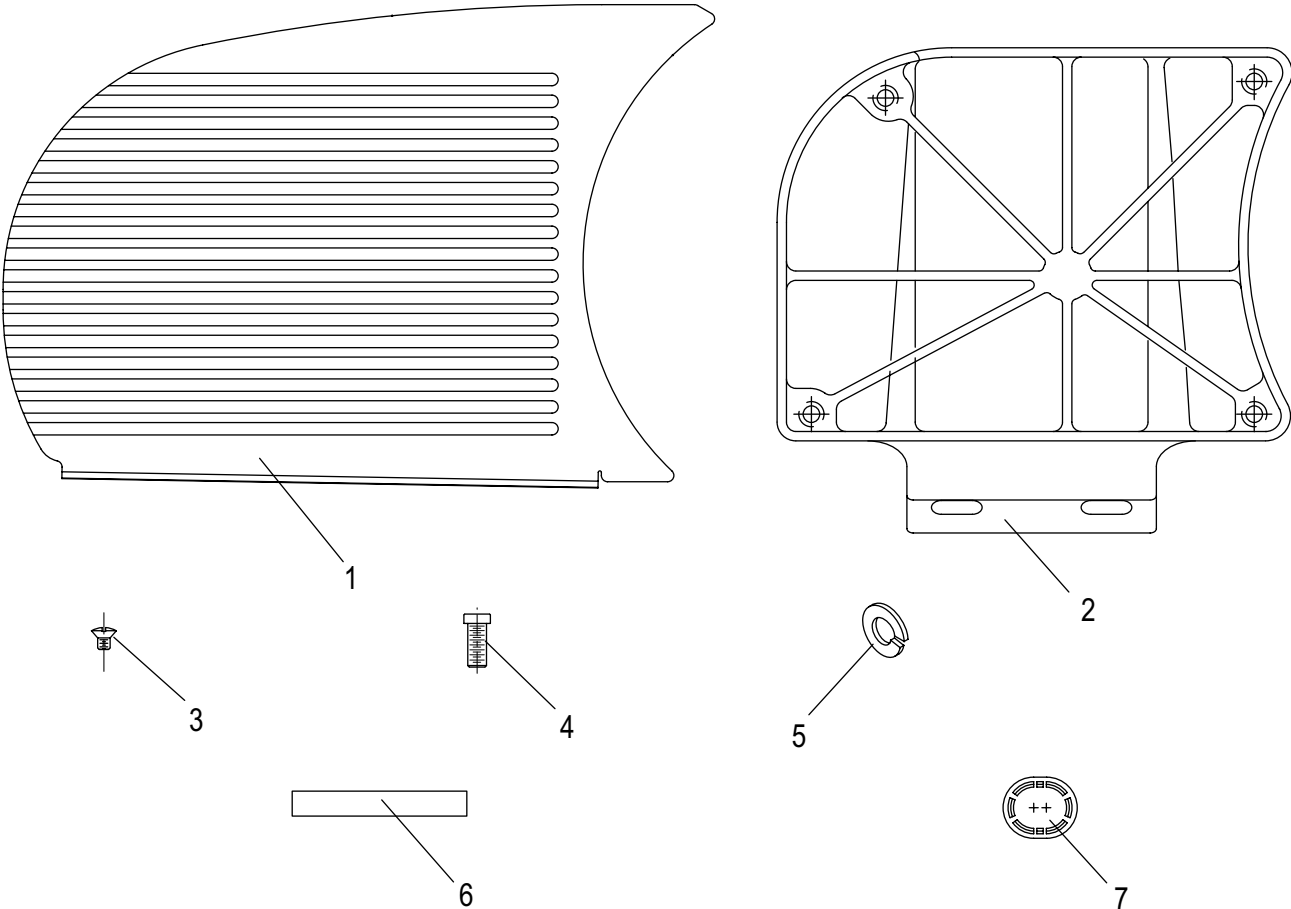

ITEM	PART DESCRIPTION	PART NUMBER	QTY.
	TABLE ASSEMBLY	1277	1
1	TABLE, STAINLESS STEEL	1168	1
2	TABLE SUPPORT	1057	1
3	TABLE FASTENER	976-1	4
4	SCREW	1058	2
5	LOCK WASHER	870020	2
6	SHIM	337-A	AS REQUIRED
7	HOLE PLUG, OVAL	520000	2

# KNIFE RIM GUARD

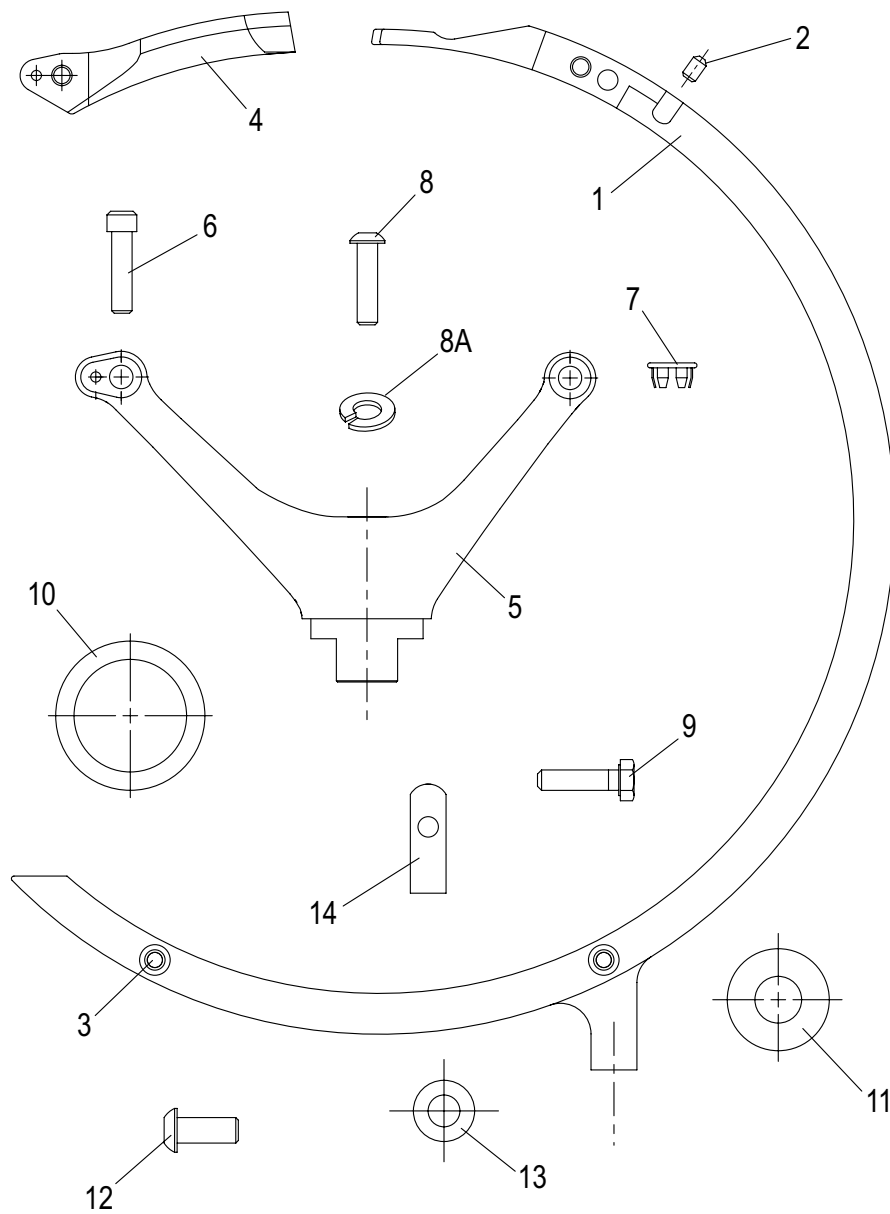

ITEM	PART DESCRIPTION	PART NUMBER	QTY
1	KNIFE RIM GUARD ASSEMBLY	1132	1
	KNIFE RIM GUARD ASSEMBLY (4975A ONLY)	250061	
2	SET SCREW	1245	1
3	LOCATOR PIN	1131	2
4	UPPER KNIFE RIM GUARD	1283	1
5	KNIFE RIM GUARD BRACKET	230000	1
6	SCREW	1238	2
7	HOLE PLUG	1211	2
8	SCREW	1217	1
8A	LOCK WASHER	1226	1
9	BOLT	810050	1
10	TRIM RING	1031	1
11	TRIM RING	1032	1
12	SCREW	1239	1
13	WASHER	763-4A	1
14	COVER	320010	1

# KNIFE COVER

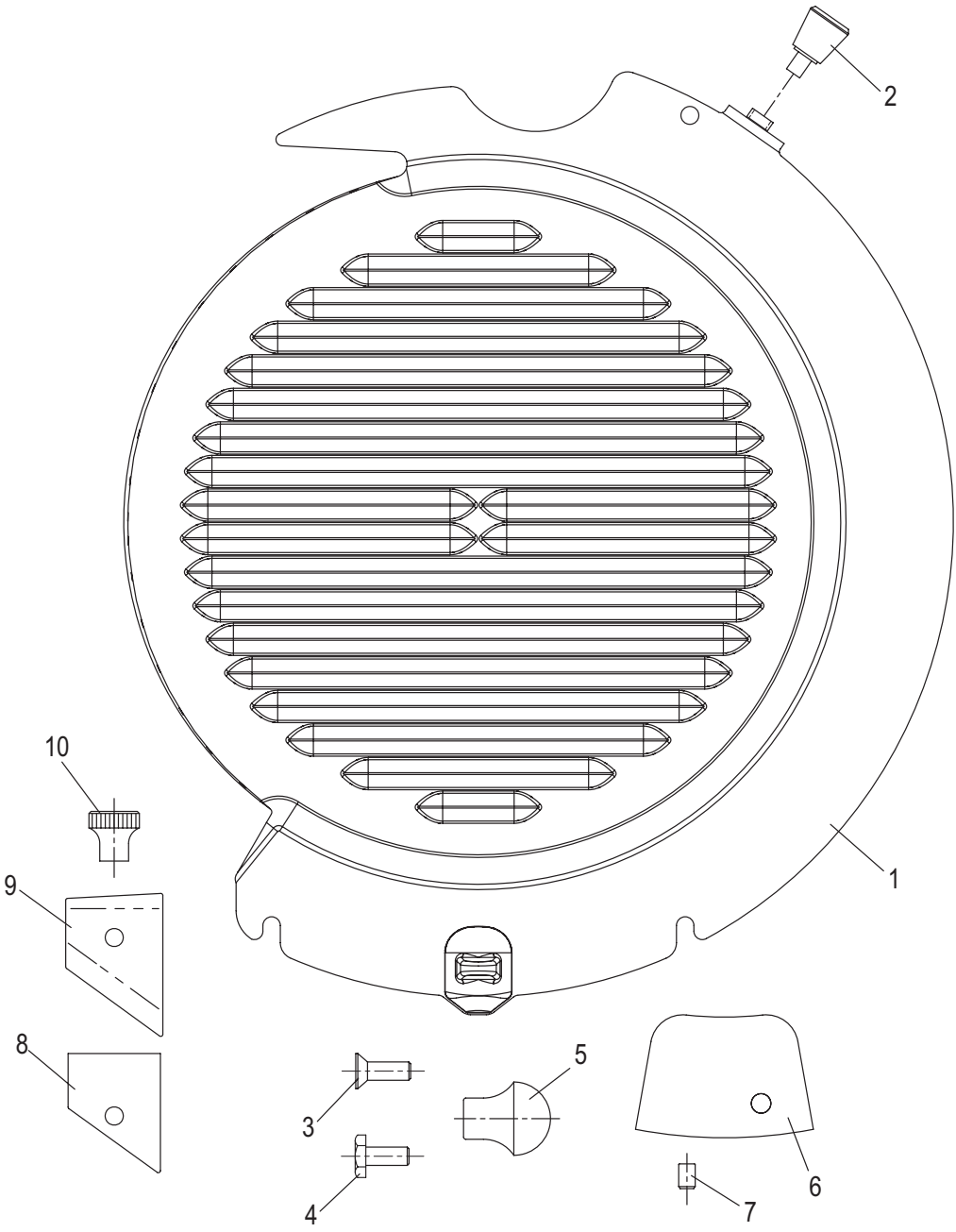

ITEM	PART DESCRIPTION	PART NUMBER	QTY
1	KNIFE COVER ASSEMBLY	310160	1
2	COVER KNOB, SPRING PLUNGER	1056	1
Items 3 thru 9: Replacement parts for obsolete Knife Covers 1139 & 320060			
3	SCREW, FLAT HEAD 4975V	1089	-
4	SCREW, HEX HEAD 4975A	810310	-
5	KNOB	1138	-
6	MAGNET BOX ASSEMBLY	1282	-
7	NYLON SCREW	1197	-
8	KNIFE SCRAPER, NYLON	520020	-
9	SCRAPER HOLD DOWN, SS	320050	-
10	SCRAPER NUT	943-2	-



# GEAR HOUSING AND KNIFE

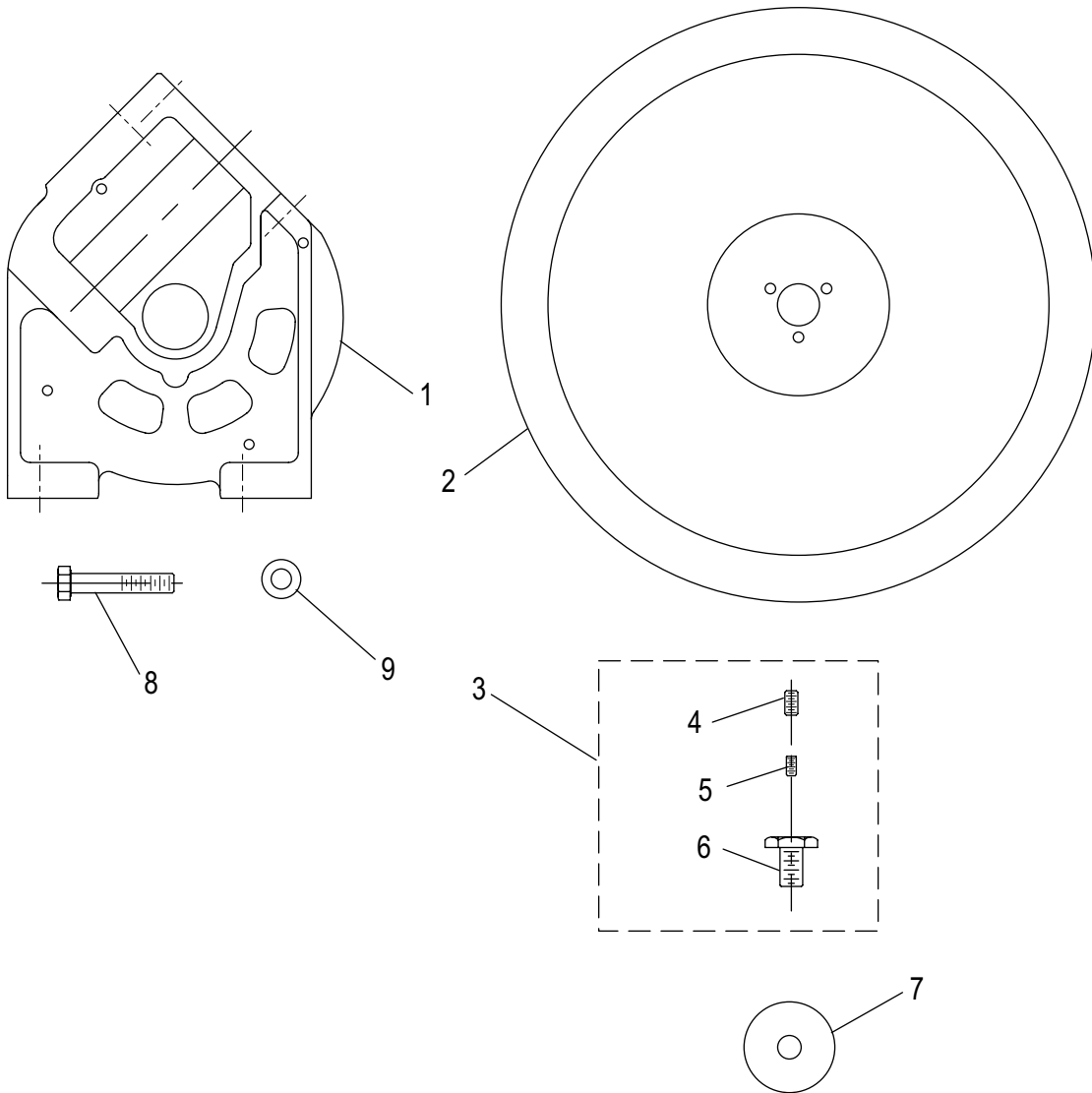

ITEM	PART DESCRIPTION	PART NUMBER	QTY
1	GEAR HOUSING	1007	1
2	CARBON KNIFE	1021	1
	CARBON KNIFE, PRESHARPENED	*460030	1
	STAINLESS STEEL KNIFE	1022	1
3	KNIFE BOLT ASSEMBLY	1195	1
4	PLUG	1193	1
5	SET SCREW	1194	1
6	BOLT	1093	1
7	FLAT WASHER	1092	1
8	HEX BOLT	369-1	1
9	FLAT WASHER	763-4A	1
10	SILICON LUBRICANT (NOT SHOWN)	521-D	1

\* USED ONLY ON MODEL 4975A

# KNIFE SHARPENER ASSEMBLY

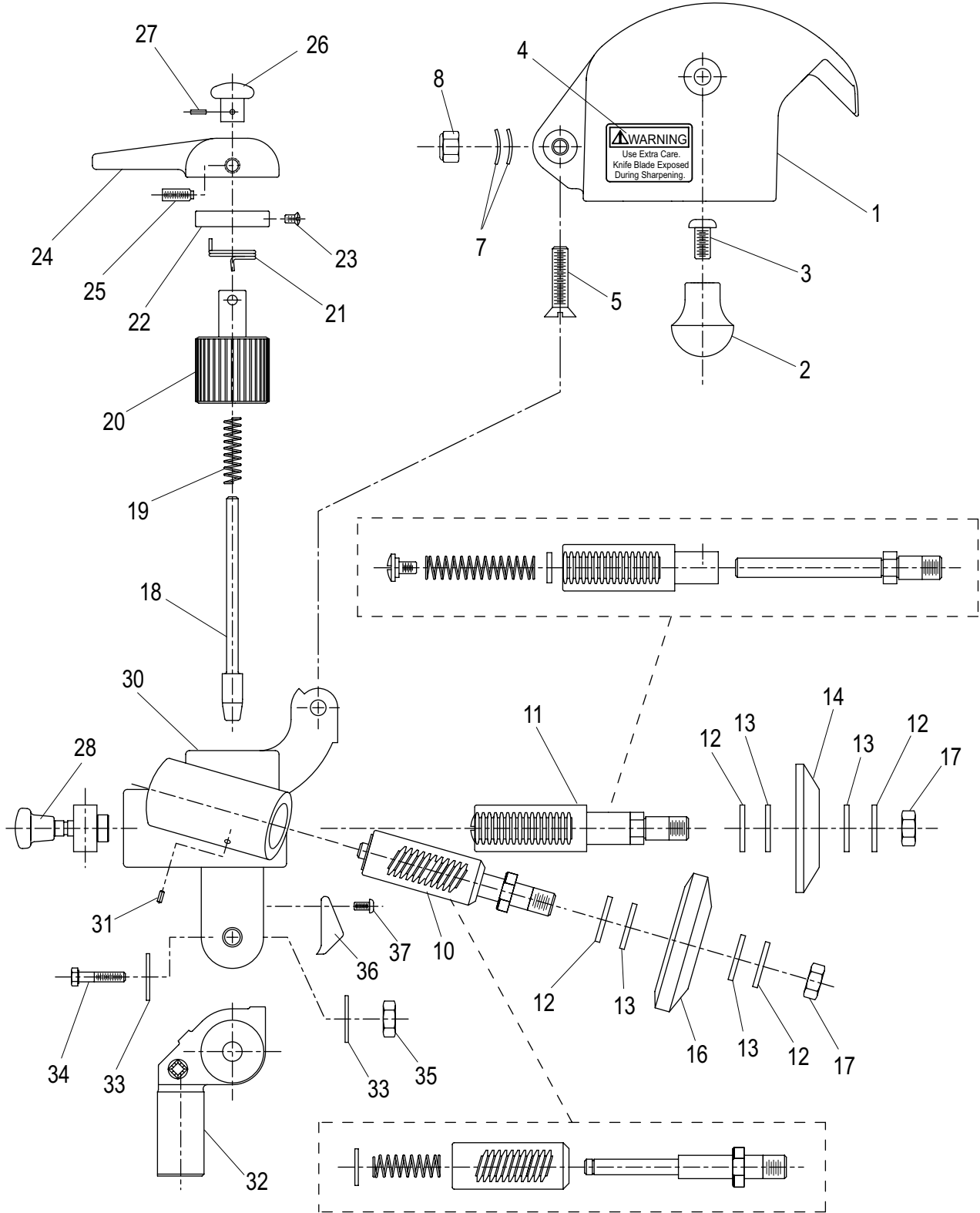

# SHARPENER ASSEMBLY PARTS LIST

ITEM	PART DESCRIPTION	PART NUMBER	QTY
	SHARPENER ASSY WITH COVER (4975A USE 070046)	070040	1
1	SHARPENER COVER	1041	1
2	SHARPENER COVER KNOB (4975A USE 510002)	1138	1
3	SHARPENER COVER COVER KNOB SCREW	1258	1
4	COVER WARNING DECAL - ENGLISH	967-2	1
	COVER WARNING DECAL - SPANISH	967-2S	1
5	COVER HINGE SCREW	825-1	1
7	COVER TENSION WASHER	761-6	2
8	COVER HINGE NUT	810266	1
9	SHARPENER ASSY W/O COVER (4975A USE 070045)	070041	1
10	GRINDING SHAFT ASSEMBLY	463-AS	1
11	TRUING SHAFT ASSEMBLY	467-AS	1
12	WASHER	229	5
13	WASHER, FIBER	229-1	4
14	TRUING STONE (4975A USE 240033)	213	1
16	GRINDING STONE (4975A USE 240032)	214-A	2
17	NUT, GROUND	810140	1
18	LOCK ROD ASSEMBLY	456-AS	1
19	LOCK SPRING	458	1
20	GEAR	455	1
21	GEAR RETURN SPRING	460	1
22	GEAR SPACER RING	459	1
23	SET SCREW	470-1	2
24	HANDLE	495	1
25	SET SCREW	495-1	1
26	LOCK KNOB	461	1
27	LOCK KNOB PIN	287-2	1
28	TRUING STONE STOP ASSEMBLY	471-AS	1
29	SHARPENER SUBASSEMBLY	-	1
30	HOUSING	450-H	1
31	SLEEVE PIN	300	1
32	BRACKET	240020	1
33	WASHER	286-1	2
34	HINGE BOLT	475	1
35	NUT	286	1
36	HOLE COVER	520060	1
37	SCREW	810280	1

# KNIFE MOTOR BEARING ASSEMBLY

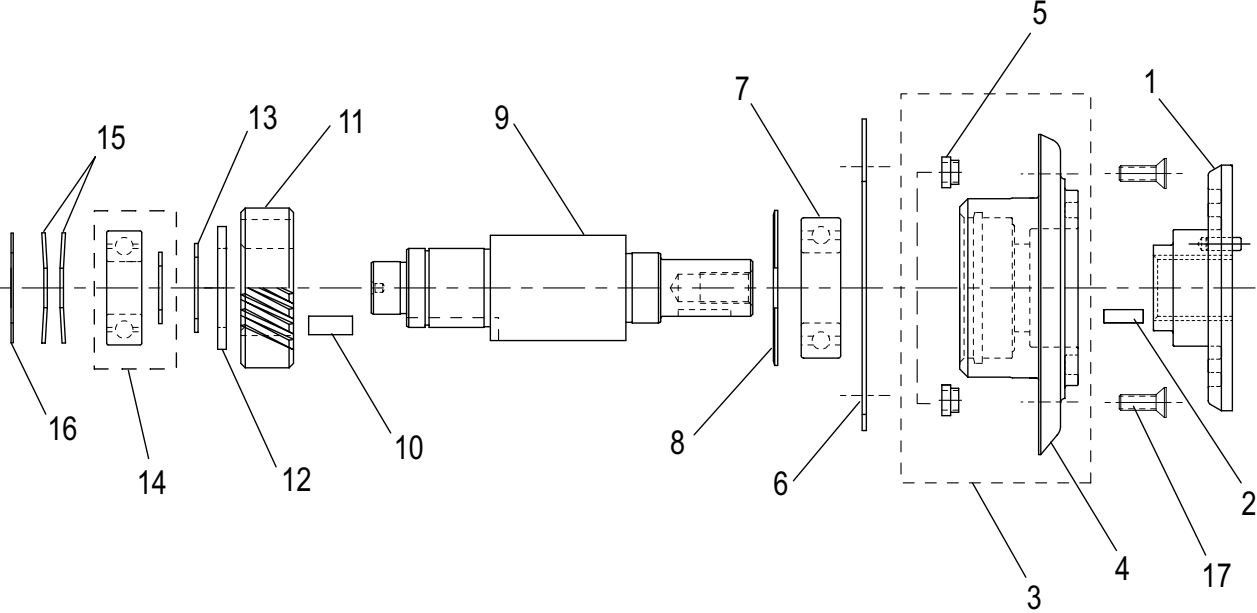

ITEM	PART DESCRIPTION	PART NUMBER	QTY
	BEARING ASSEMBLY	1094	1
1	KNIFE LOCATING HUB ASSEMBLY	1090	1
2	KEY	1106	1
3	UPPER BEARING RETAINER ASSEMBLY	1037-AS	1
4	UPPER BEARING RETAINER	1037	1
5	STANDOFF	1237	4
6	RETAINER, SHROUD GASKET	1241	1
7	BEARING	972-5P	1
8	RETAINING RING	1088	1
9	KNIFE SHAFT	1085	1
10	KEY	1086	1
11	GEAR	1084	1
12	SPACER	1083	1
13	RETAINING RING	1087	1
14	BEARING AND SPACER	972-8P	1
15	BOWED WASHER	1215	2
16	THRUST WASHER	1221	1
17	SCREW, FLAT HEAD	1089	4

# TABLE ADJUSTMENT COMPONENTS

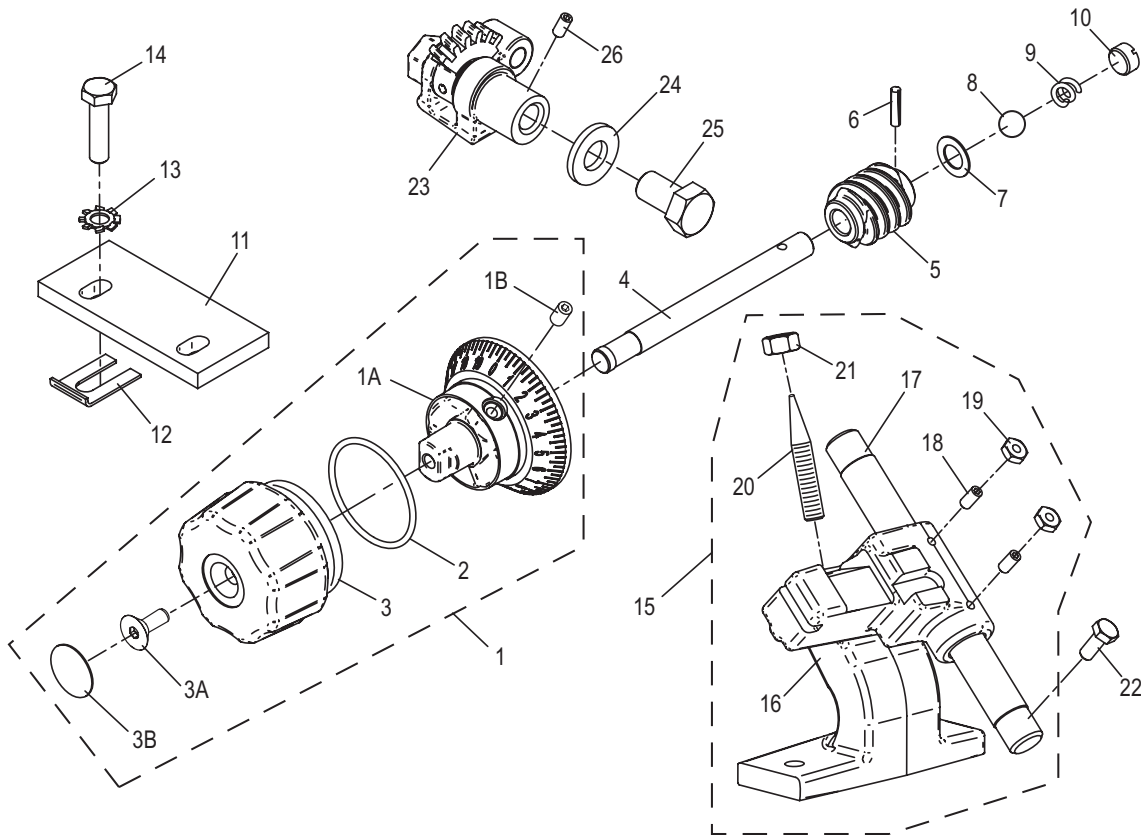

ITEM	DESCRIPTION	PART NUMBER	QTY
1	TABLE ADJUSTMENT KNOB	510020	1
1A	KNOB DIAL	510023	1
1B	SET SCREW	810320	3
2	O-RING	840025	1
3	KNOB CAP	510021	1
3A	SCREW, FLAT HEAD	810325	1
3B	SCREW COVER	910175	1
4	TABLE ADJUSTMENT KNOB SHAFT	864	1
5	WORM GEAR	1147	1
6	PIN, WORM GEAR	360	1
7	WASHER, WORM GEAR	359	1
8	BALL	362	1
9	SPRING, TENSION	1200	1
10	THRUST SCREW	361-1	1
11	SLIDE GUIDE	1259	1
12	SLIDE GUIDE SHIM (VARIOUS THICKNESS)	349-A.001 - 349-A.052	AS REQD
13	LOCK WASHER	870000	2
14	SCREW, HEX HEAD	1307	2
15	TABLE SLIDE ASSEMBLY	200040	1
	TABLE SLIDE ASSEMBLY, SS SHAFT	200041	
16	TABLE SLIDE	1033	1
17	TABLE SLIDE SHAFT	1027	1
	TABLE SLIDE SHAFT, STAINLESS STEEL	1281	
18	SET SCREW	168-1	2
19	NUT	760-5	2
20	STOP SCREW	430000	1
21	STOP SCREW NUT	478-1	1
22	SCREW, HEX HEAD	975-1	1
23	TABLE ADJUSTING GEAR ASSEMBLY	453-AS	1
24	FLAT WASHER	881-4	1
25	HEX SCREW	335	1
26	SET SCREW	700-3	2
27	TABLE SLIDE ROD SHIM (NOT SHOWN)	870040	1

# TABLE SLIDE SYSTEM COMPONENTS

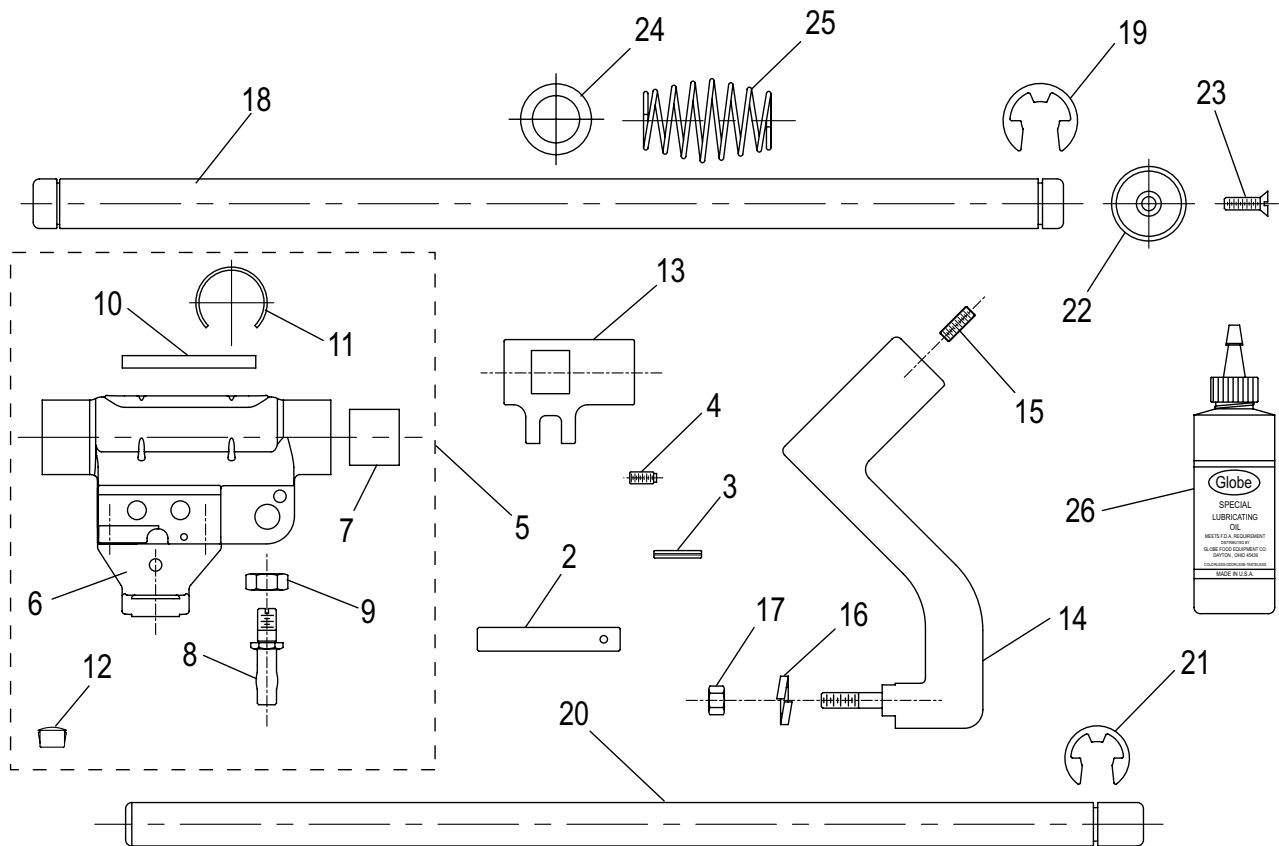

ITEM	PART DESCRIPTION	PART NUMBER	QUANTITY REQD	
			MANUAL	AUTO
1	UPPER SLIDE ASSY - AUTOMATIC	1278-A	-	1
2	CHAIN SLIDE SHAFT	1079	-	1
3	ROLL PIN	1235	-	1
4	SET SCREW	1270	-	2
5	UPPER SLIDE ASSEMBLY - MANUAL	1278	1	-
6	UPPER SLIDE ASSY	-	1	1
7	SLIDE BUSHING	436-7	2	2
8	STUD, SLIDE ROD BUSHING	241-B	1	1
9	NUT	228	1	1
10	FELT, OIL	436-3	1	1
11	SPRING CLIP	436-4	2	2
12	PLUG	850-3	1	1
13	LOWER SLIDE BUSHING	1342	1	1
14	CHUTE RECEIVER ASSY	250100	1	1
15	SCREW	167-1	1	1
16	LOCKWASHER	245-A	2	2
17	NUT	478-2	2	2
18	UPPER SLIDE ROD	420050	1	1
19	UPPER RETAINING CLIP	857-1	1	1
20	LOWER SLIDE ROD	420060	1	1
21	LOWER RETAINING CLIP	858-1	1	1
22	SLIDE BAR WASHER	859	2	2
23	SCREW	859-1	2	2
24	SLIDE BUMPER	436-1	1	-
25	SPRING, UPPER SLIDE ROD	919-4	1	2
26	LUBRICATING OIL	519	1	1

# KNIFE MOTOR COMPONENTS

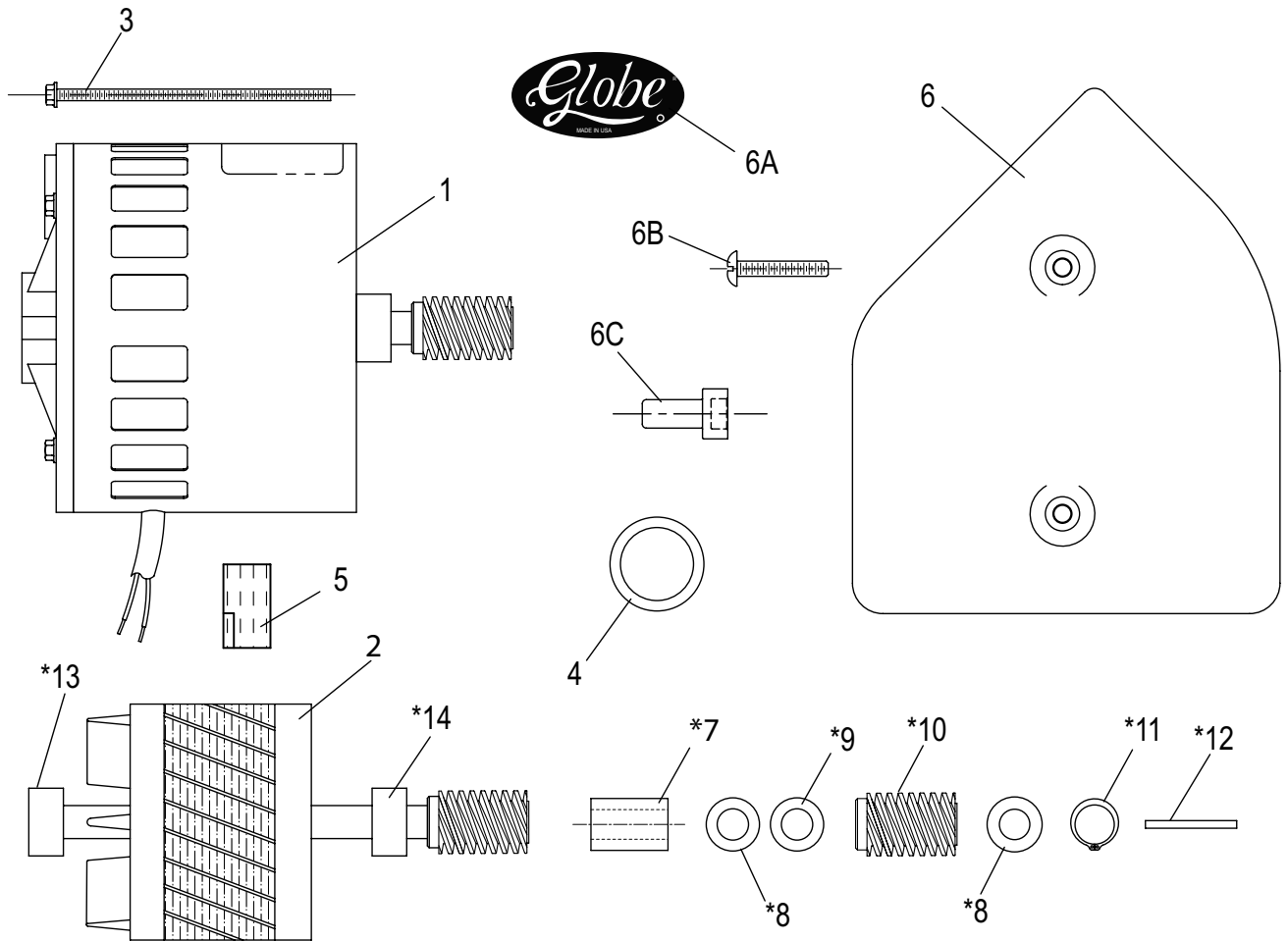

ITEM	DESCRIPTION	PART NUMBER	QTY
1	MOTOR ASSEMBLY 115VAC/60HZ/1PH	1049	1
	MOTOR ASSEMBLY 115VAC/60HZ/1PH W/RESET	1322	1
	MOTOR ASSEMBLY 230VAC/50HZ/1PH W/RESET	1323	1
2	MOTOR ROTOR & END BELL 115VAC/60HZ/1PH	420003	1
	MOTOR ROTOR & END BELL 115VAC/60HZ/1PH W/RESET	420004	1
†2A	MOTOR END BELL (NOT SHOWN)	450003	1
3	MOTOR SCREW	1205	4
4	BOWED WASHER	1317	1
5	WIRE CONNECTOR	982-1MH	1
6	MOTOR COVER	1142	1
	MOTOR COVER W/RESET HOLE	1311	1
6A	LABEL, GLOBE LOGO	871-2	1
6B	SCREW	1253	2
6C	MOTOR RESET BUTTON	1214	1
*7	SPACER	1363	1
*8	FLAT WASHER	870070	2
*9	BOWED WASHER	810	1
*10	WORM GEAR	1059	1
*11	SNAP RING	880051	1
*12	KEY, SQUARE	1372	1
*13	BEARING	-	1
*14	BEARING, DRIVE END	-	1
15	THRUST WASHER (NOT SHOWN)	1221	1

\* PARTS INCLUDED WITH ITEMS 1 & 2.

† USE WITH LARGE (47mmDIA) BEARING

# STAINLESS STEEL CHUTE AND SUPPORT

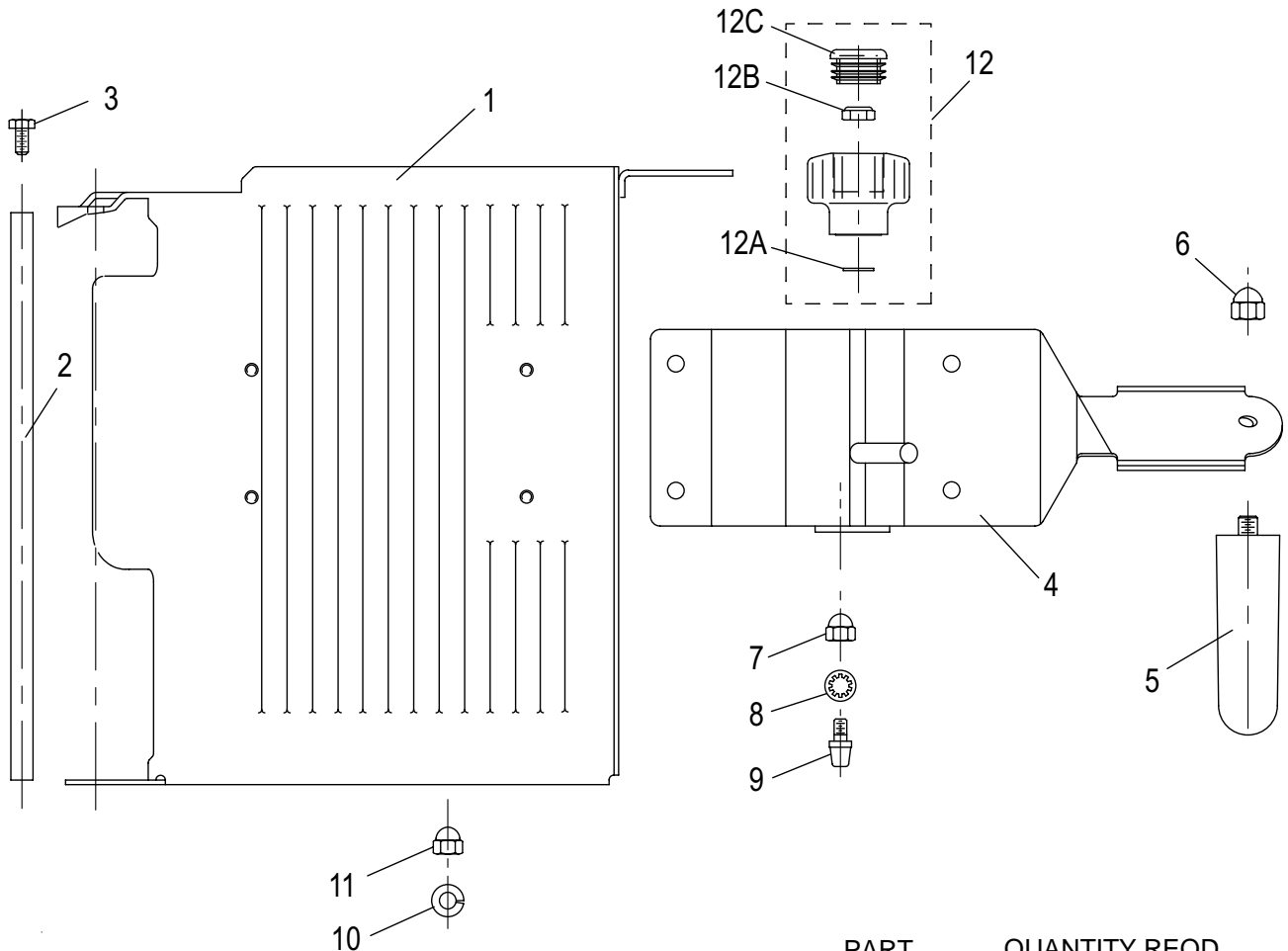

ITEM	PART DESCRIPTION	PART NUMBER	QUANTITY REQD		
			AUTO	MAN	4975A
*	14.5" SS CHUTE ASSEMBLY WITH PRONGS	102-AS-17	-	1	
	12" SS CHUTE ASSEMBLY WITH PRONGS	102-AS-19	1	-	
	12" SS CHUTE ASSEMBLY WITHOUT PRONGS	102-AS-20	-	1	-
1	12" CHUTE	962-S	1	-	
	14.5" CHUTE	962-M	-	1	
2	END WEIGHT ROD - 11-3/16" LONG	962-18S	1	-	
	END WEIGHT ROD - 13-11/16" LONG	962-18M	-	1	
3	SCREW	962-17		2	
4	CHUTE SUPPORT	330050		1	
5	CHUTE HANDLE	482-B		1	
6	ACORN NUT	699-32		2	
7	ACORN NUT	962-7		1	
8	LOCK WASHER, INTERNAL TOOTH	962-19		1	
9	LOCK BACK STUD	962-5		1	
10	LOCK WASHER	962-16		6	
11	ACORN NUT	962-6		4	
12	CHUTE SECURITY NUT (NOT SHOWN)	810265	-	-	-
	CHUTE SUPPORT KNOB	510011		1	
12A	LOCK WASHER	-		1	
12B	NYLOCK NUT	-		1	
12C	CAP	-		1	

\* CHUTE ASSEMBLY INCLUDES END WEIGHT.



# END WEIGHTS

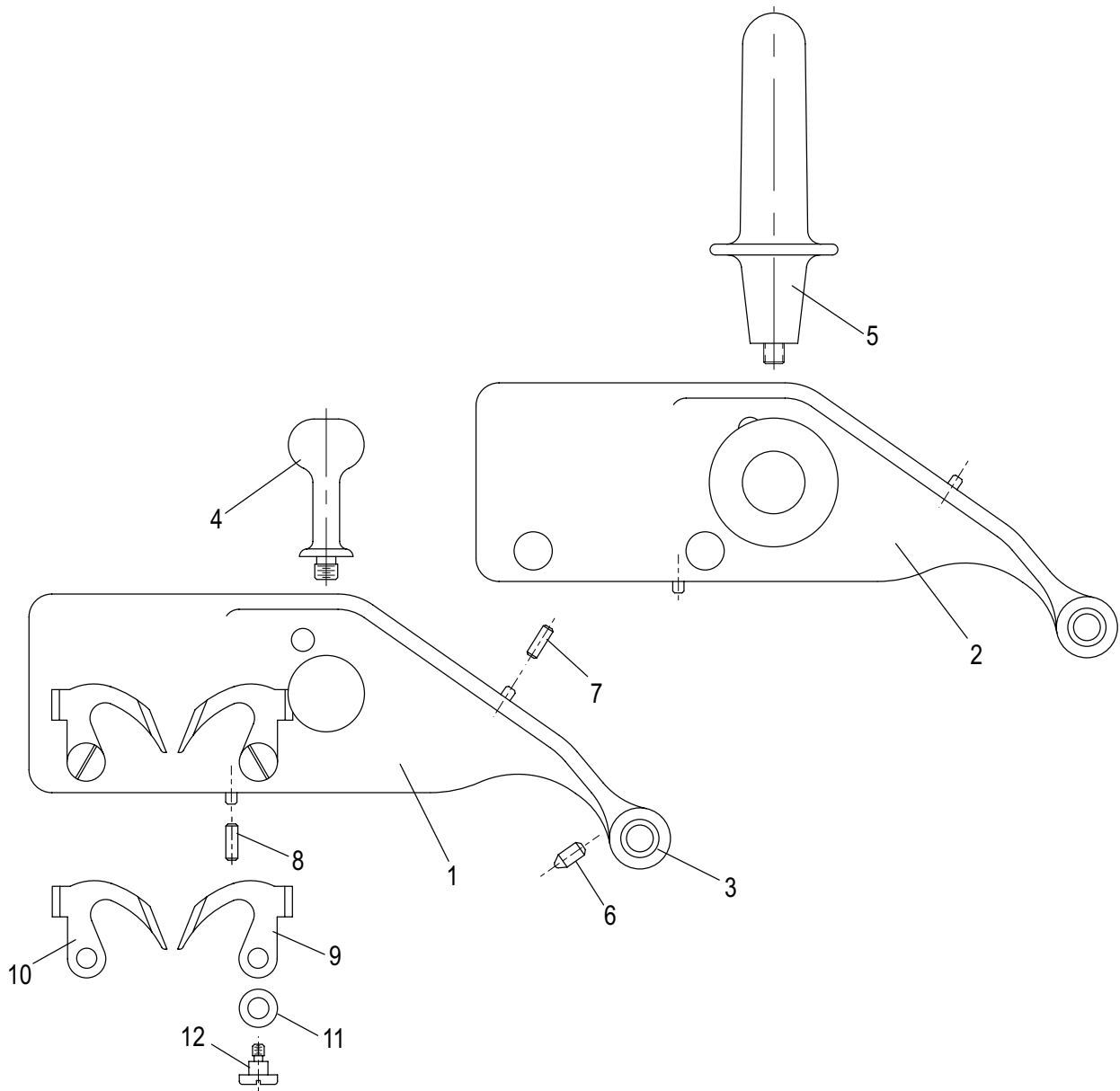

ITEM	PART DESCRIPTION	PART NUMBER	QUANTITY REQD		
			AUTO	MANUAL	4975A
	END WEIGHT ASSEMBLY, SS - W PRONGS	741-SS-AA	-	-	1
	END WEIGHT ASSEMBLY, SS - W/O PRONGS	741-SS-AS	-	1	-
	END WEIGHT ASSEMBLY, SS - W/PRONGS	741-SS-APC	1	-	-
1	*AUTOMATIC END WEIGHT, SS	1233	1	-	1
2	*MANUAL END WEIGHT, SS	1234	-	1	-
3	END WEIGHT BUSHING	741-6	2	2	2
4	END WEIGHT HANDLE, PLASTIC	510012	1	1	-
4A	END WEIGHT HANDLE, SS (4975A ONLY)	741-SS3	-	-	1
5	END WEIGHT REST BUMPER	741-4A	1	1	1
6	END WEIGHT SPACER BUMPER	741-5A	1	1	1
7	END WEIGHT CHUTE BUMPER	741-5B	1	1	1
8	END WEIGHT PRONG, RIGHT	741-PC2	1	-	1
9	END WEIGHT PRONG, LEFT	741-PC3	1	-	1
10	SPRING WASHER, PRONG	741-PC5	8	-	8
11	SHOULDER SCREW, PRONG	741-SS4	2	-	2

\* END WEIGHT INCLUDES ITEM 3 (BUSHINGS)

# MANUAL SLICER ELECTRICAL SYSTEM (REV B)

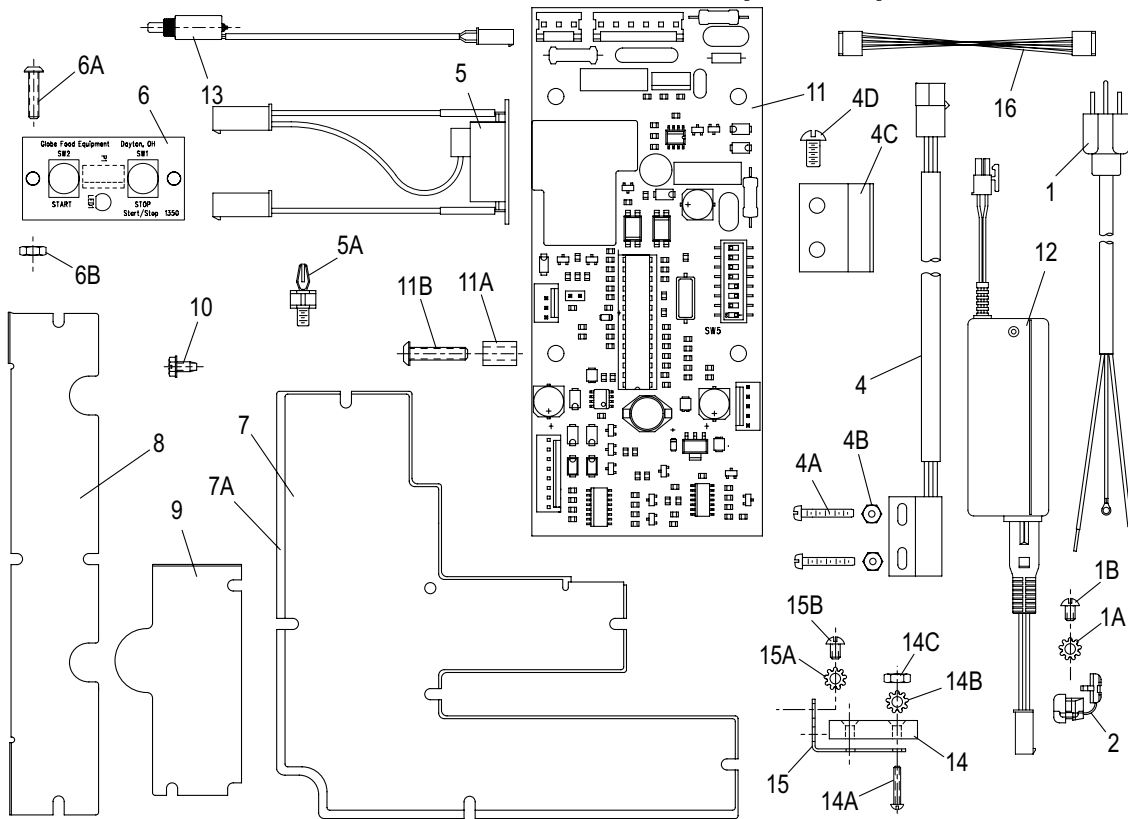

ITEM	PART DESCRIPTION	PART NUMBER	QTY
1	POWER CORD	132-3	1
1A	LOCK WASHER	854-7	2
1B	SCREW	854-6	2
2	STRAIN RELIEF, POWER CORD	877	1
3	WIRING HARNESS, 110VAC (NOT SHOWN)	130121	1
4	PROXIMITY SWITCH (HOME, TIMER & KNIFE GUARD)	130020	3
4A	SCREW	995-31	4
4B	NUT	854-3	4
4C	BRACKET, SWITCH MOUNTING - KNIFE GUARD	1133	1
4D	SCREW	1223	2
5	MOTOR START SWITCH ASSY, SOLID STATE, 110VAC	130050	1
5A	STAND-OFF, MOTOR START SWITCH	1250	2
6	CIRCUIT BOARD, START/STOP	1350	1
6A	SCREW	1218	2
6B	NUT	765-5	2
7	COVER, WIREWAY	320020	1
7A	GASKET, WIREWAY COVER	1192	1
8	COVER, WIREWAY # 2	1136	1
9	COVER, WIREWAY # 3	1137	1
10	SCREW, WIREWAY COVER	889	14
11	CIRCUIT BOARD, LOGIC	120033	1
11A	STAND-OFF	1216	4
11B	SCREW	1218	4
12	POWER SUPPLY, 24V	130060	1
13	SOLENOID ASSY, TABLE LOCK-OUT	130090	1
14	MAGNET, INTERLOCK	985-1	1
14A	SCREW	854-2	2
14B	LOCK WASHER	854-7	2
14C	NUT	854-3	2
15	BRACKET, MAGNET MOUNTING	1341	1
15A	LOCK WASHER	854-7	2
15B	SCREW	854-6	2
16	JUMPER CABLE	1377	1

# AUTOMATIC SLIDE SYSTEM

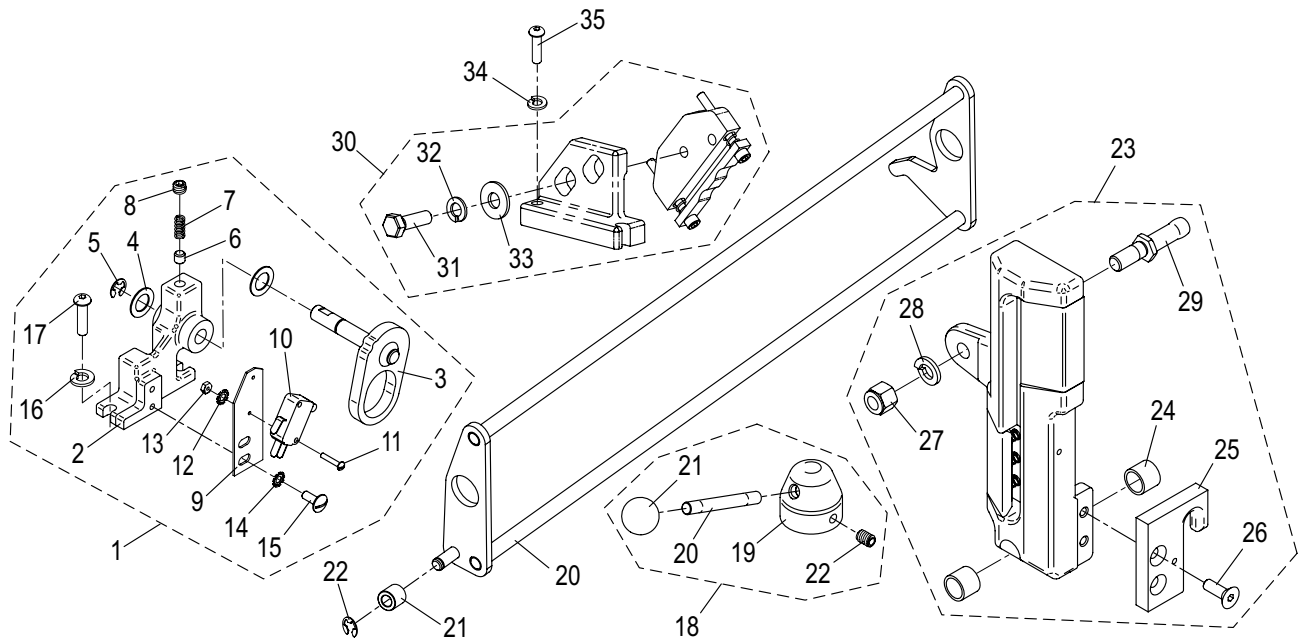

ITEM	PART DESCRIPTION	PART NUMBER	QTY
1	AUTO/MANUAL LEVER ASSEMBLY	1360	1
2	BRACKET, AUTO ENGAGE	1055	1
3	CAM ASSEMBLY	1145	1
4	FIBER WASHER	359	2
5	C-CLIP	940-10	1
6	PLUG	1299	1
7	SPRING	1300	1
8	SET SCREW	1291	1
9	BRACKET, MICROSWITCH	1053	1
10	MICROSWITCH	1263	1
11	SCREW	854-2	2
12	LOCK WASHER	854-7	2
13	NUT	854-3	2
14	LOCK WASHER	854-7	2
15	SCREW	900-1	2
16	LOCK WASHER	1226	2
17	SCREW, BUTTON HD	1217	2
18	AUTO-ENGAGE LEVER ASSEMBLY	1029	1
19	LEVER HUB	1026	1
20	SHAFT	1028	1
21	KNOB	1202	1
22	SET SCREW	810002	1
23	CHAIN SLIDE ASSEMBLY	1308	1
24	BEARING	1166	2
25	ACTUATOR	1119	1
26	SCREW	1089	2
27	LOCK NUT	1297	1
28	LOCK WASHER	962-13	1
29	ECCENTRIC STUD	1080	1
30	ENGAGEMENT SPRING ASSEMBLY	1361	1
31	SCREW	1295	2
32	LOCK WASHER	245-A	2
33	FLAT WASHER	1288	2
34	LOCK WASHER	1226	2
35	SCREW, BUTTON HD	1217	2
36	ROCKER ASSEMBLY	1104	1
37	CAM ROLLER	1102	1
38	C-CLIP	940-10	1

# AUTOMATIC SLICER TABLE DRIVE SYSTEM

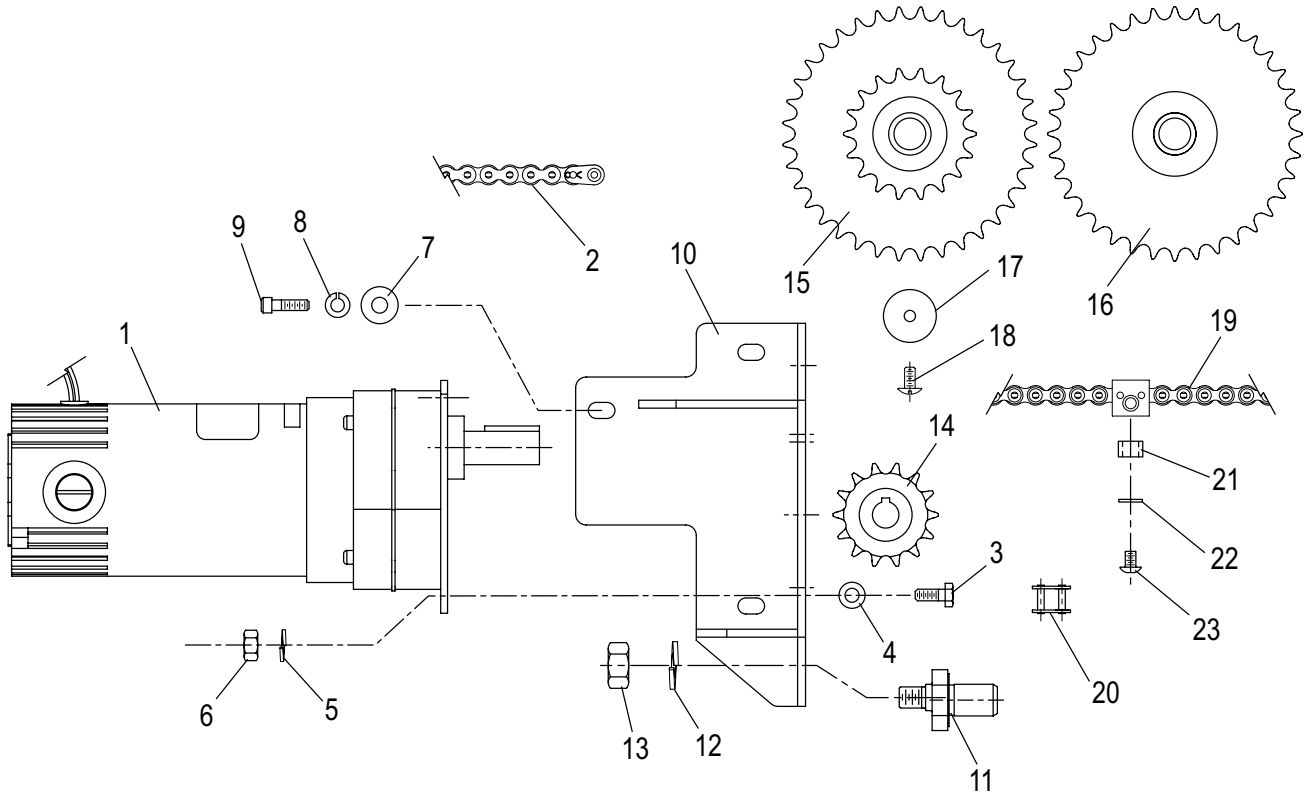

ITEM	PART DESCRIPTION	PART NUMBER	QTY
1	DC GEAR MOTOR	982-1BS	1
2	DRIVE CHAIN	1019	1
3	SCREW	627-C	4
4	FLAT WASHER	825-2	4
5	LOCK WASHER	962-16	4
6	NUT	825-3	4
7	FLAT WASHER	1288	3
8	LOCK WASHER	245-A	3
9	CAP SCREW	1298	3
10	MOTOR MOUNT BRACKET	1082	1
11	SPROCKET STUD	1118	2
12	LOCK WASHER	815	2
13	NUT	646	2
14	MOTOR SPROCKET	1030	1
15	18 & 36 TOOTH SPROCKET	1285	1
16	36 TOOTH SPROCKET	1286	1
17	SPROCKET WASHER	608	2
18	SCREW	762-6	2
19	AUTO DRIVE CHAIN ASSEMBLY	1020	1
20	MASTER LINK	1336	1
21	CAM FOLLOWER	1097	1
*22	CAM SCREW	1107	1
23	FLAT WASHER, CAM	870084	1
24	WIRE CONNECTOR (NOT SHOWN)	982-1MH	1

\*MUST SHIP WITH WASHER P/N 870084 (ITEM 23).

# AUTOMATIC BASE APRON & LIFT LEVER ASSMEBLY

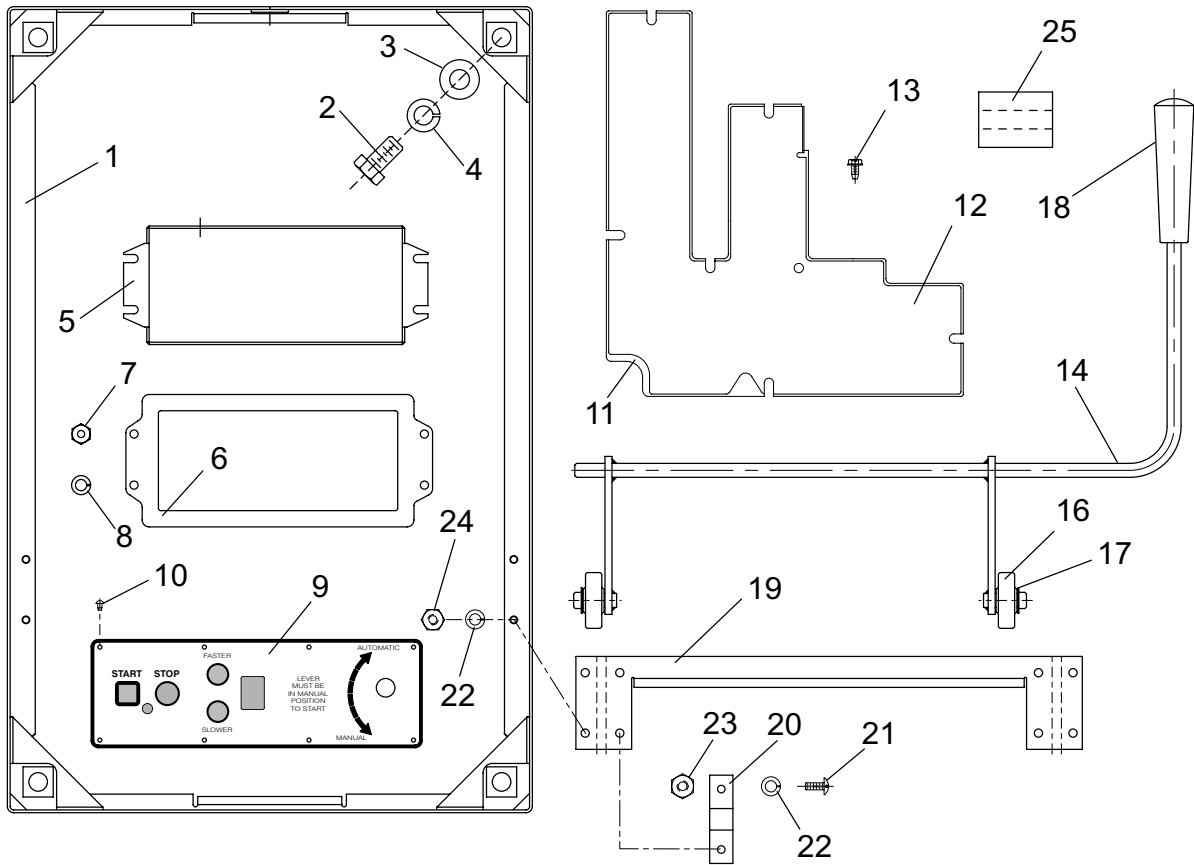

ITEM	PART DESCRIPTION	PART NUMBER	QTY
1	BASE APRON, AUTOMATIC SLICER	1046	1
	BASE APRON, MANUAL SLICER	310080	
2	BOLT	813	4
3	FLAT WASHER	881-4	4
4	LOCK WASHER	815	4
5	COVER, ELECTRICAL BOX	1228	1
6	GASKET	1274	1
7	NUT	1276	4
8	LOCK WASHER	1252	4
9	OVERLAY, TOUCH PAD (4975A USE 910032)	1159	1
10	DRIVE SCREW	851-6P	8
11	GASKET	1192	1
12	COVER, WIRE WAY	320041	1
13	SCREW	889	7
14	LIFT LEVER ASSEMBLY	1161	1
15	LIFT LEVER	1154	1
16	WHEEL	951-7	2
17	CLIP	1156	2
18	HANDLE	951-8	1
19	SUPPORT, LIFT LEVER	1155	1
20	PIVOT ROD CLIP	951-2	2
21	SCREW	900-1	4
22	LOCK WASHER	1252	8
23	NUT	1276	4
24	NUT	760-5	4
25	CLIP, BOTTOM COVER	550010	1
26	COVER, BOTTOM (NOT SHOWN)	340000	1
27	LABEL, WIRING DIAGRAM (NOT SHOWN)	910041	1

# AUTOMATIC SLICER ELECTRICAL SYSTEM

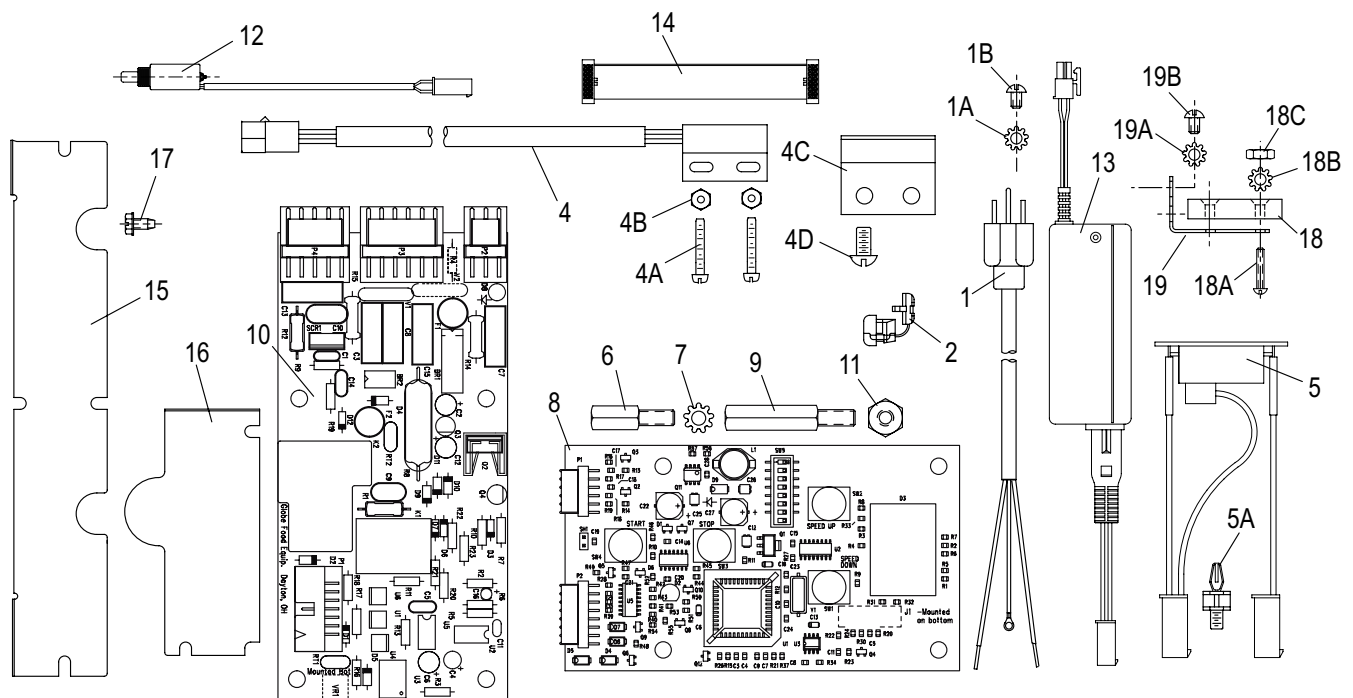

ITEM	PART DESCRIPTION	PART NUMBER	QTY
1	POWER CORD	132-3	1
1A	LOCK WASHER	854-7	2
1B	SCREW	854-6	2
2	STRAIN RELIEF, POWER CORD	877	1
3	WIRING HARNESS, 110VAC (NOT SHOWN)	130200	1
4	PROXIMITY SWITCH (HOME, TIMER & KNIFE GUARD)	130020	3
4A	SCREW	995-31	4
4B	NUT	854-3	4
4C	BRACKET, SWITCH MOUNTING - KNIFE GUARD	1133	1
4D	SCREW	1223	2
5	MOTOR START SWITCH ASSY, SOLID STATE, 110VAC	130050	1
5A	STAND-OFF, MOTOR START SWITCH	1250	2
6	STANDOFF	1294	4
7	LOCK WASHER	854-7	4
8	CIRCUIT BOARD, START/STOP (4975A USE 120030)	120032	1
9	STANDOFF	1293	4
10	CIRCUIT BOARD, POWER CONTROL	1344	1
11	NUT	1219	4
12	SOLENOID ASSY, TABLE LOCK-OUT	130090	1
13	POWER SUPPLY, 24V	130060	1
14	RIBBON CABLE	1367	1
15	COVER, WIREWAY # 2	1136	1
16	COVER, WIREWAY # 3	1137	1
17	SCREW, WIREWAY COVER	889	7
18	MAGNET, INTERLOCK	985-1	1
18A	SCREW	854-2	2
18B	LOCK WASHER	854-7	2
18C	NUT	854-3	2
19	BRACKET, MAGNET MOUNTING	1341	1
19A	LOCK WASHER	854-7	2
19B	SCREW	854-6	2

# VEGETABLE HOPPER ACCESSORY

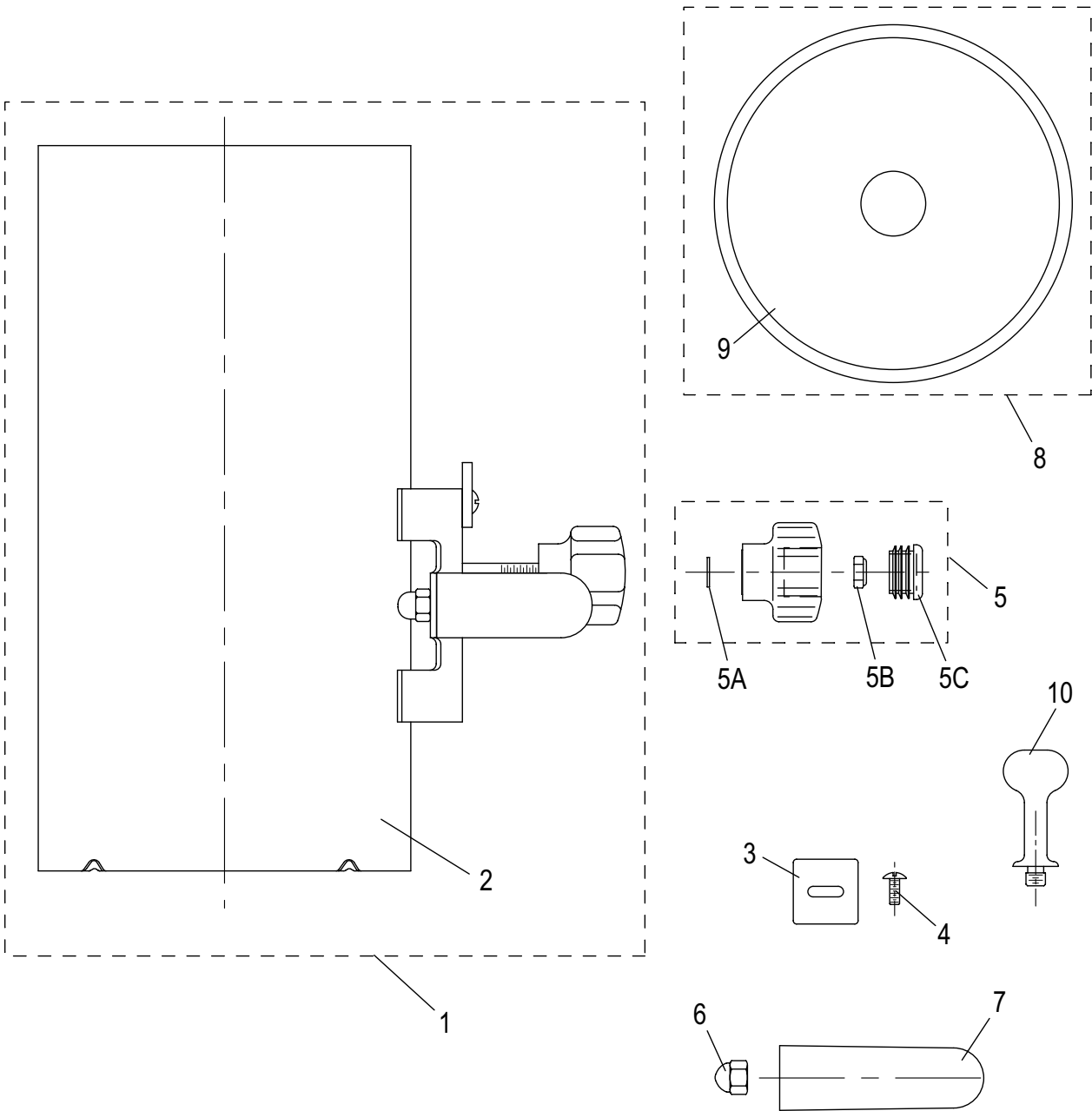

ITEM	PART DESCRIPTION	PART NUMBER	QTY
1	VEGETABLE HOPPER ASSEMBLY	699-BAS	1
2	HOPPER BODY WITH SUPPORT AND STUD	030041	1
3	HOPPER STOP	699-33	1
4	HOPPER STOP SCREW	900-1	1
5	HOPPER NUT	510011	1
5A	FLAT WASHER	-	1
5B	NYLOCK NUT	-	1
5C	CAP	-	1
6	ACORN NUT	699-32	1
7	HOPPER HANDLE	482-B	1
8	HOPPER END WEIGHT ASSEMBLY	699-16	1
9	HOPPER END WEIGHT	699-17	1
10	HOPPER END WEIGHT HANDLE	699-18	1

# FRONT MOUNTED END WEIGHT CHUTE ASSEMBLY

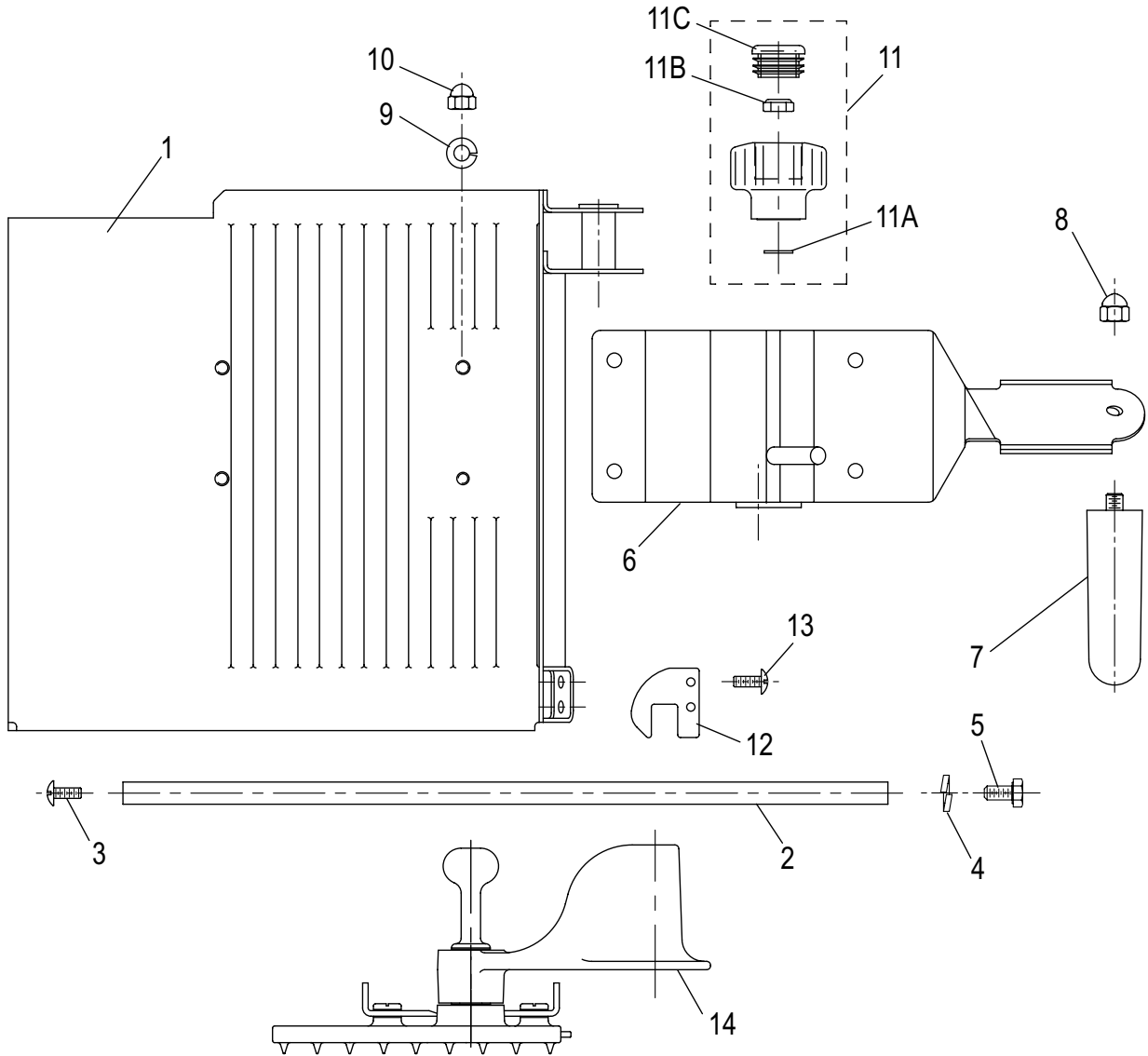

ITEM	PART DESCRIPTION	PART NUMBER	QTY
	CHUTE ASSY W/FRONT MOUNTED END WEIGHT	102-AS-21	1
1	FRONT MOUNTED END WEIGHT CHUTE	981	1
2	END WEIGHT ROD	981-1	1
3	SCREW	981-2	1
4	LOCK WASHER	962-13	1
5	SCREW	981-9	1
6	CHUTE SUPPORT	330050	1
7	CHUTE HANDLE	482-B	1
8	ACORN NUT	699-32	1
9	LOCK WASHER	962-16	4
10	ACORN NUT	962-6	4
11	CHUTE SUPPORT NUT	510011	1
11A	FLAT WASHER	-	1
11B	NYLOCK NUT	-	1
11C	CAP	-	1
12	ENDWEIGHT REST	981-4	1
13	SCREW	900-1	2
14	END WEIGHT ASSY, FRONT MOUNTED	981-3	1



# CHUTE FENCE ACCESSORIES

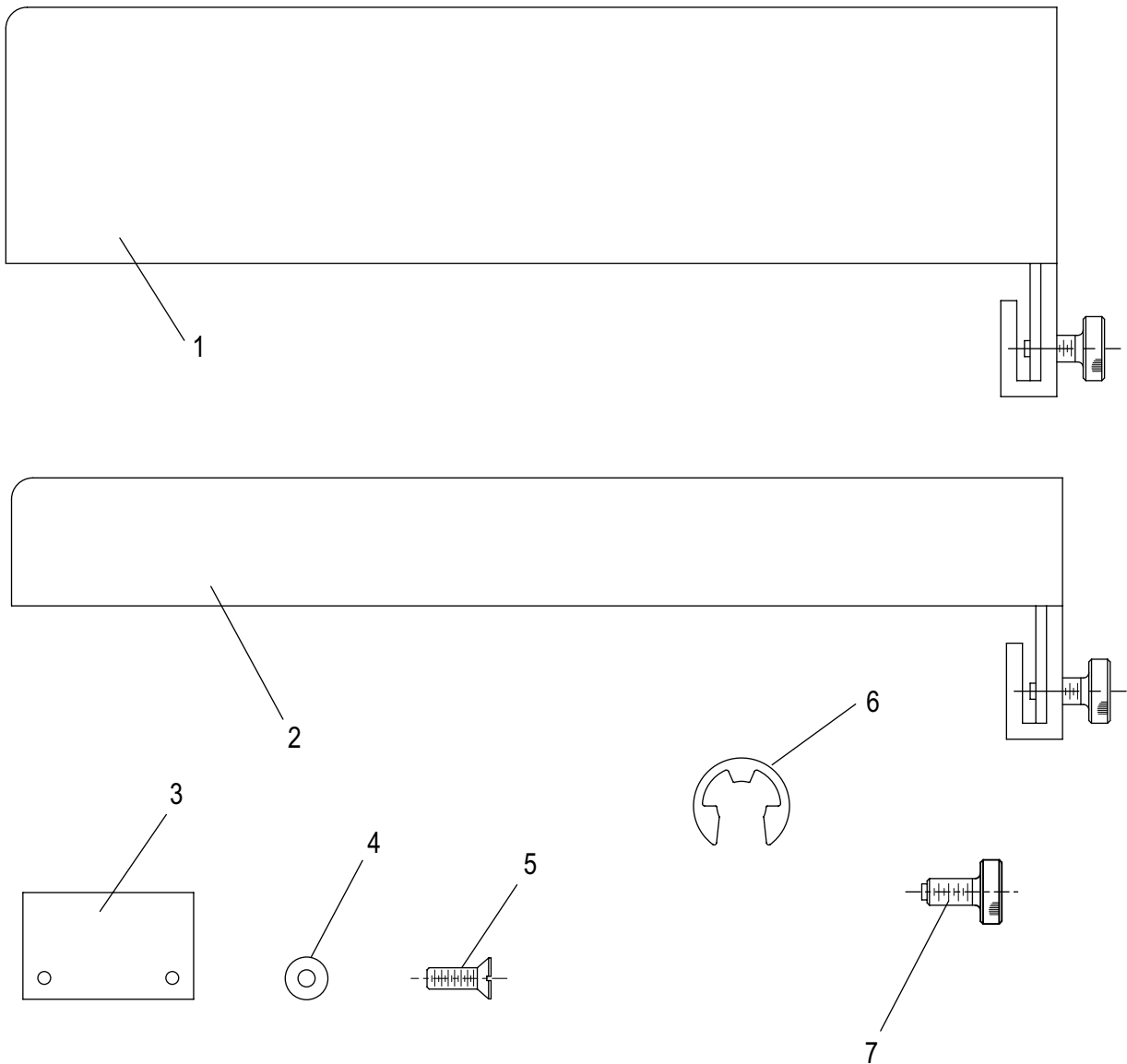

ITEM	DESCRIPTION	PART NUMBER	QTY
	FENCE ASSEMBLY, 12" X 3"	1326	1
	FENCE ASSEMBLY, 12" X 1-3/8"	1047	1
1	FENCE, 12" X 3"	1048	1
2	FENCE, 12" X 1-3/8"	1051	1
3	FENCE CLAMP	940-5	1
4	CLAMP SPACER	940-7	2
5	CLAMP MOUNTING SCREW	699-25	2
6	RETAINING RING	940-10	1
7	CLAMP THUMB SCREW	1052	1

# MANUAL SLICER SCHEMATIC - MODEL 4600

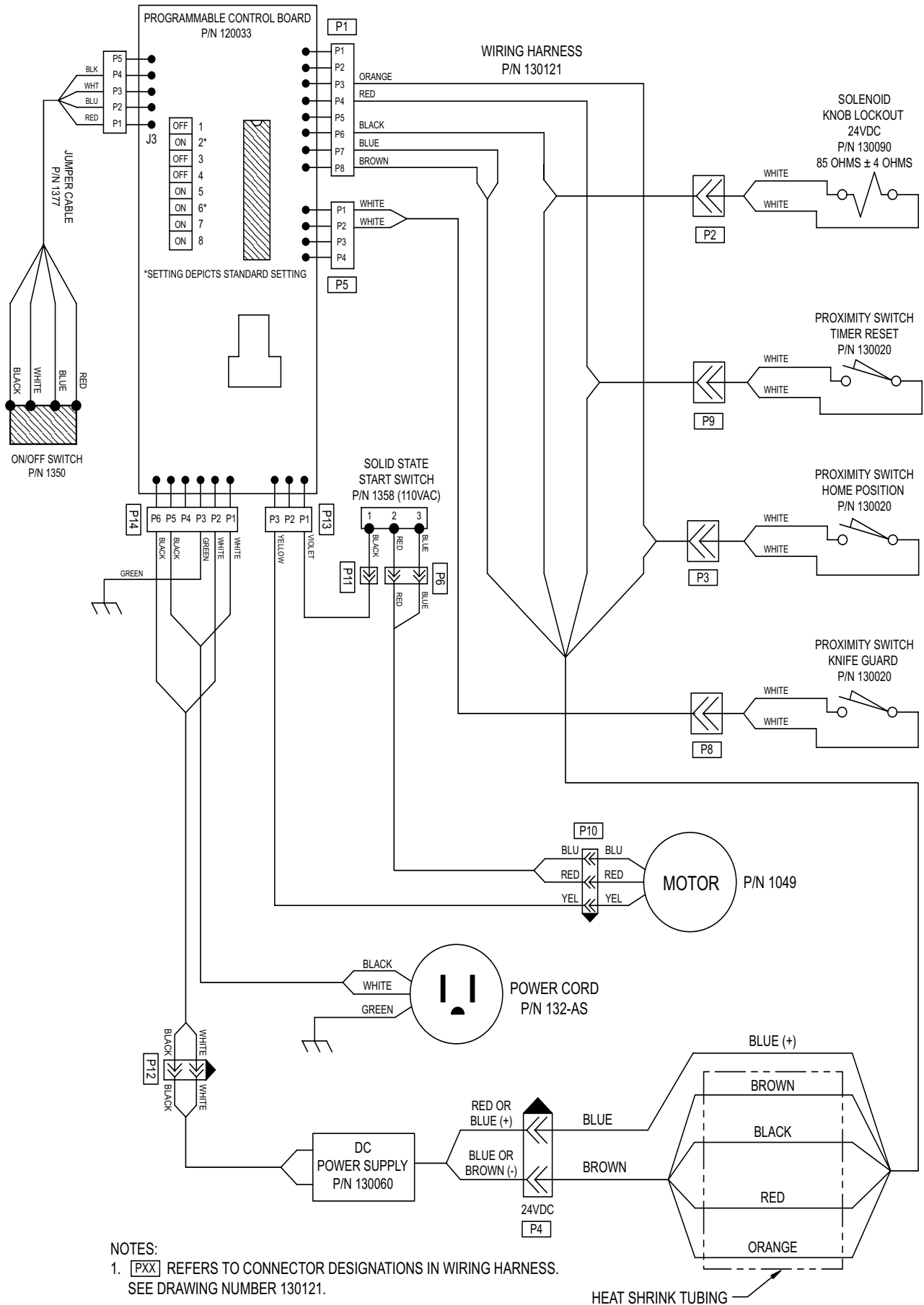

- NOTES:
1. [PXX] REFERS TO CONNECTOR DESIGNATIONS IN WIRING HARNESS. SEE DRAWING NUMBER 130121.

# AUTOMATIC SLICER SCHEMATIC - MODELS 4975 & 4975A

